



EsiWelma s.r.l.

Sensigas®

Oxygen detectors

IP55 protection rating

URS20SL



11...28Vdc power supply.

Electrochemical cell sensor designed for the detection of oxygen (O₂).

Up to three alarm thresholds plus sensing element fail.

LED on sensing element body to indicate operating status.

Automatic countdown of sensor life.

Use

The URS20SL detectors are used to detect oxygen excess or deficiency in non-classified areas.

An **oxygen excess** forms if it leaks in hospitals, laboratories, welding centres and, more in general, where oxygen is stored.

Oxygen deficiency is an indirect measurement of the presence of other explosive or asphyxiant gases that deplete the oxygen in the air.

URS20SL sensors can be used in stand-alone mode with 4...20mA output or with an optional voltage-free contact relay card having the following four digital outputs:

- Pre-alarm, 1st alarm threshold, 2nd alarm threshold, sensor fail.

Operation

If there is an oxygen leak or an absence of oxygen, the detector compares the measured concentration value with the threshold limit setpoints and energises the associated relays. Information on the measured concentration value is always at the 4...20mA output.

Ordering

To order, simply state the part number: **URS20SL**.

For special versions, on request, please contact Customer Service.

Technical characteristics

| | | |
|---|--|---|
| Type of sensor | Electrochemical cell | |
| Detectable Gas | O ₂ excess | O ₂ deficiency |
| Power supply | 11÷28Vdc | |
| Max power consumption | 2.5W | |
| Measuring range | 0...30% O ₂ | |
| Precision | ± 2,5% of full scale range (in air) | |
| Repeatability | ± 2,5% of full scale range | |
| Measurement resolution | 0.1% O ₂ | |
| Microprocessor resolution | 1024 points (10 bit) | |
| Digital filter system | Kalman Filter | |
| Watchdog | Internal | |
| Warm-up time | < 2m | |
| Stabilization time | < 2m | |
| Response time | < 10s (T20), < 45s (T90) | |
| Average Sensor life (in air) | 120 weeks | |
| Sensor type settings (O ₂ excess or deficiency) | S1.7 DIP switch OFF (O ₂ excess) | S1.7 DIP switch ON (O ₂ deficiency) |
| Threshold limit settings (S1.8 = OFF, default): | | |
| | Pre-alarm | 23% O ₂ |
| | 1 st threshold alarm | 25% O ₂ |
| | 2 nd threshold alarm | 27% O ₂ |
| | | 19% O ₂ |
| | | 17% O ₂ |
| | | 15% O ₂ |
| Threshold limit settings (S1.8 = ON): | | |
| | Pre-alarm | 22% O ₂ |
| | 1 st threshold alarm | 23% O ₂ |
| | 2 nd threshold alarm | 24% O ₂ |
| | | 20% O ₂ |
| | | 19% O ₂ |
| | | 18% O ₂ |
| 4...20mA Output | | |
| Proportional mode (default) | - 4mA = 0% O ₂ | - 20mA = 30% O ₂ |
| Consumption mode (applications at 1 or 2 thresholds) | - 0mA = no alarm | - 10mA = 1 st threshold alarm |
| 4...20mA Output reference selection: | - 20mA = 2 nd threshold alarm | |
| 4...20mA output load resistor | by jumper selectable polarity | |
| | - up to 200Ω at 12Vdc power supply | |
| | - 200Ω ÷ 700Ω at 24Vdc power supply | |
| Operating Temperature | -20 ÷ 50 °C | |
| Storage Temperature | -20 ÷ 70 °C | |
| Relative Humidity (without condensing) | | |
| - Operation | 15 ÷ 90 %RH | |
| - Storage | 45 ÷ 75 %RH | |
| Operating pressure (KPa) | 80 ÷ 110 | |
| Air speed (m/s) | ≤ 6 | |
| Visual warnings | Red LED visible with detector energised | |
| Dimensions and weight | See dedicated section | |
| <u>Options & Accessories</u> | | |
| Card with 4 SPDT relays UZR20.4 | See threshold limit settings | |
| NO or NC contacts available, jumper selectable | | |
| Maximum relay capacity: | 50mA at 24Vac/dc, 100mA at 12Vac/dc | |
| Relay operating mode: | - direct: relay ON when an event is detected | |
| | - reverse: relay ON when no event is detected | |
| TUL40.. Gas calibration kit | See installation and commissioning chapter | |
| TUS40 Handheld terminal for service and maintenance | See installation and commissioning chapter | |
| CRG40 gas collecting cone | See dedicated data sheet | |
| PAP40 deluge protection | See dedicated data sheet | |
| <u>EC Conformity</u> | | |
| EMC Directives / Standards, | Electromagnetic Compatibility Directive EMC 2004/108/EC, Standard EN50270 | |
| LVD Directives / Standards | Not applicable | |

Sensors lifetime

Sensor average lifetime (see technical characteristics) is referred to a typical usage in a pollution-free environment. Presence of a high concentration of pollutants can shorten the lifetime of the sensing element.

Once the detection system starts up, it has to be supplied with energy during all the lifetime of its sensors.

Seasonal use of the detection system is not recommended.

Installation**Oxygen excess**

Since oxygen weighs more or less the same as air, unless there is forced or natural air circulation, it tends to spread at the point of the leak.

So, the excess oxygen detectors must be installed near any likely leakage points, in order to detect the excess oxygen as quickly as possible.

Oxygen deficiency

Detection of oxygen deficiency has the purpose of indirectly detecting the presence of other gases that deplete the oxygen in the air, therefore causing asphyxiation problems, for example.

In this case, the detectors must be located at the breathing height of the occupants in the premises.

Take into consideration the following specific installation guidelines, as well as the above instructions, for location of the detectors.

The detectors must be installed:

1. where accidental gas leakages are possible
 2. at least 1.5m away from heat sources or from vent holes
 3. not in spaces where ventilation is poor and where gas pockets may form
 4. away from hindrances to natural gas flow
 5. away from equipment that may leak gas during normal operations
 6. in environments with a temperature range of -20°C to 50°C and relative humidity below 90% (non-condensing)
 7. Disconnect equipment from the power supply when mounting and dismantling detectors.
-

Electrical Installation

CAUTION: Make the area safe and make sure that the device power supply is off before cabling and configuration operations.

Install the sensor in compliance with laws in force.
The cable gland provided on the housing is used for cable entry.
Ground the sensor using the internal grounding system.

Terminal board and electrical connections

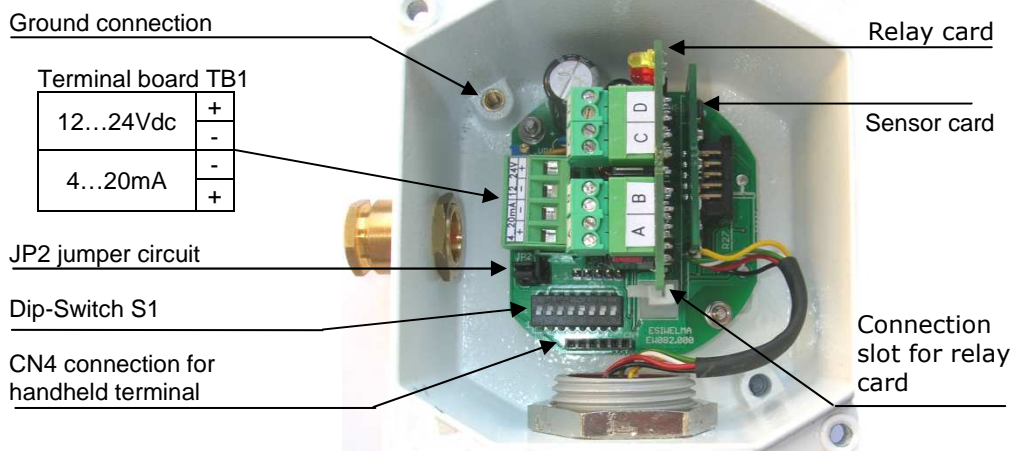

Cabling:

Depending on the connecting distance, use at least 3-core cable, min. diameter 0.75mm² up to 100m, 1mm² up to 200m, 1.5mm² up to 500m.
Use shielded cable where there is a risk of electromagnetic interference.
If a relay card is used, use multi-core cable suitable for the number of connections.

Configuration:

Default settings of the sensor are shown in the "Technical Specifications" chapter.
In order to change the default settings, switch off the power supply, input the new settings at the JP2 jumper circuit or at the S1 DIP switch as shown in the diagram, then power-up again; in particular:

4...20mA Output reference selection:

The default setting for the 4-20mA signal is the negative power signal. Output reference selection should be made by JP2 triple of jumpers; to change this setting, operator has to move **JP2** jumpers as shown in the figure:

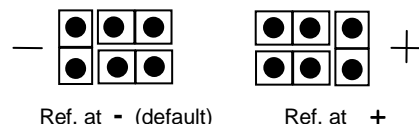

Caution: if the default settings are changed, the connections on the **TB1** terminal board will be inverted.

4...20mA signal operating mode configuration:

To set the operating mode of the 4...20mA signal, it is necessary to use the 5th selector of the DIP switch at **S1**; in particular:



Setting threshold limit values:

To set the threshold limit values of the optional relay card, or of the threshold operating mode of the 4...20mA signal, it is necessary to use the last selector of the DIP switch at **S1** (ignore the first four selectors); in particular, the thresholds, given in percentage of O₂, will be:

| | O ₂ excess | O ₂ deficiency |
|---------------------------------|-----------------------|---------------------------|
| (S1.8 = OFF, default): | | |
| Pre-alarm | 23% O ₂ | 19% O ₂ |
| 1 st threshold alarm | 25% O ₂ | 17% O ₂ |
| 2 nd threshold alarm | 27% O ₂ | 15% O ₂ |
| (S1.8 = ON): | | |
| Pre-alarm | 22% O ₂ | 20% O ₂ |
| 1 st threshold alarm | 23% O ₂ | 19% O ₂ |
| 2 nd threshold alarm | 24% O ₂ | 18% O ₂ |

Mechanical installation of the optional relay card

The control card can be expanded with a relay card inserted into a dedicated connector **CN3** with four SPDT relays that will be activated under the following conditions: pre-alarm, 1st threshold alarm 2nd threshold alarm and sensor fail, and relative LED alerts.

To install the card, follow the instructions below:

Step 1:

Insert the connection slot provided with the relay card into the control card, making sure the flexible tab is towards the main terminal board. Find CN3 connector.

CN3 connector
 Connection slot (flexible tab)



Step 2:

Fit the relay card snugly and pull the flexible tab of the connection slot towards the main terminal board.

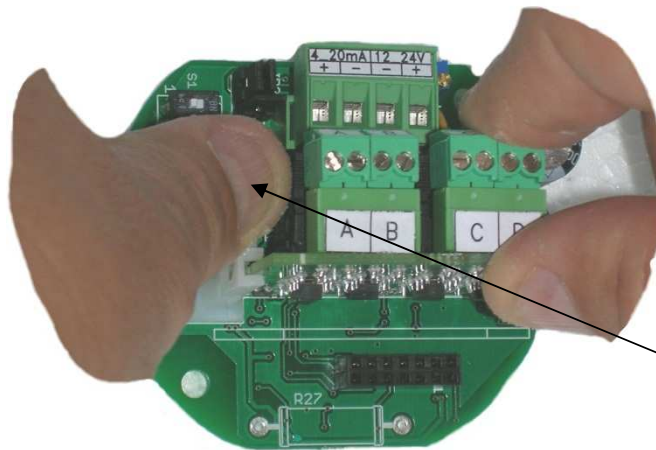

Flexible tab

Step 3:

Check the position of the card. Make sure that all the card pins fit into the CN3 connector and push slightly upwards to check that the flexible tab on the connection slot keeps the card in place.

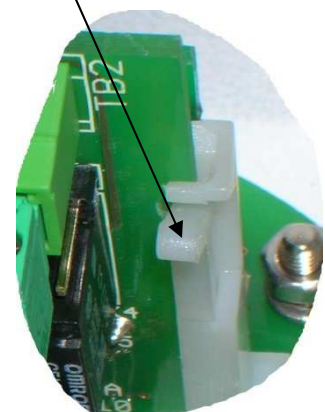

| | | |
|---------------------------------------|---|--|
| EsiWelma srl | | |
| TYPE URS20SL | | |
| $V_{max}: 28 V_{dc}$ $P_{max}: 2,5 W$ | | |
| 12V 100mA (24V 50mA) | | |
| IP55 | $-20 \leq T_a \leq +50 \text{ } ^\circ\text{C}$ | |

Step 4:

Tick the check box with a permanent marker to indicate the presence of the relay card in the device

Electrical installation of the optional relay card

After mechanically installing the relay card, it is necessary to configure it electrically, selecting the relay operating mode and the type of contact desired on the terminal board (NC or NO).

Selecting the type of contact on the terminal board:

A pair of extractable terminals is available for each relay; the type of contact (NC or NO) to be associated with them can be selected using the **JP1...JP4** jumpers.

NC or NO contact of pre-alarm relay
 NC or NO contact of 1st THRESHOLD relay
 NC or NO contact of 2nd THRESHOLD relay
 NC or NO contact of FAIL relay

DL1 (yellow), Sensor FAIL
 DL2 (red), 2nd alarm THRESHOLD
 DL3 (red), 1st alarm THRESHOLD
 DL4 (red), Pre-alarm

Selecting the terminal contact:

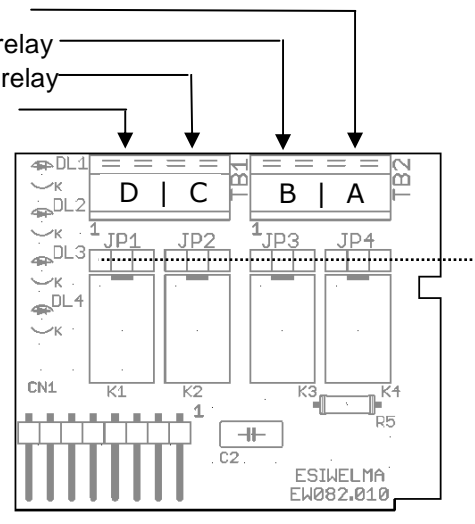

Configuring the relay operating mode:

To set the operating mode of the relays: for direct (relay energised by event) or reverse (relay energised with no event), it is necessary to use the 6th selector of the DIP switch at **S1**; in particular:

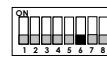

direct operating mode



reverse operating mode

Checklist after mechanical and electrical installation

The sensors are factory calibrated so they normally do not require any other calibration once installed. Still, after installation, an operational check of the sensors is recommended.

The detector will enter a 2-minute warm-up phase after power-up.

After this time, the sensor will switch to normal operating mode, but it will take about 2 hours before it reaches top performance level.

When the detector is operating, a gas response check should be carried out using the **TUL40..** gas calibration kit. This kit contains:

- 1 calibration gas cylinder: 4% of O₂; (see kit part numbers on the specific technical data sheet)
- pressure valve and flow regulator
- sensor body adapter
- about 2 metres of hose between cylinder and adapter.

During the test, check the output current, the status of the LED outside the enclosure on the sensor body and, if present the status of the LEDs on the relay card before closing the housing.

The LED on the housing and the 4...20mA output have the following operating meaning:

| Sensor status | 4...20mA Output | Status LED on housing |
|---------------------------------|--------------------------------------|------------------------------|
| WARM-UP | 2mA | Flashing at 2Hz frequency |
| OPERATING | 4...20mA | 1 flash about every 10 sec. |
| PRE-ALARM | | 2 flashes about every 5 sec. |
| 1 st ALARM THRESHOLD | 0,10,20mA for threshold applications | 3 flashes about every 5 sec. |
| 2 nd ALARM THRESHOLD | | 4 flashes about every 5 sec. |
| SENSOR FAIL | 22mA | Steady |

Checklist after mechanical and electrical installation (continued)

Since the sensor scale is between 0.....30% O₂, in air (20.9% O₂) the 4.....20mA output must be set between 14 and 16mA (theoretic value 15.1mA).

Use the calibration kit to apply the gas mixture at 4% of CO₂, making sure the 4...20mA output is between 5 and 7mA (theoretic value 6.1mA); the status LED and the pre-alarm, 1st and 2nd alarm threshold relays on the optional relay card switch on according to the thresholds and the alarm mode settings.

Maintenance

A sensor functional test should be carried out every three-six months.

Routine

Routine maintenance involves repeating the same tests as set forth in "checklist after mechanical and electrical installation".

Corrective

If any abnormalities are found during routine sensor maintenance, return the sensor concerned to the supplier / installer, who in turn will send it back to the manufacturer.

Sensors may need to be re-calibrated, using the **TUL40..** calibration kit and the **TUS40-20** handheld terminal, which must be connected to the sensor via the communication interface integrated in the cable (on the connector **CN4**).

For the re-calibration procedure, see the instructions supplied with the handheld terminal.

Decommissioning

Remove power from the detector, disconnect all wiring and conduits and dismount the housing from all the blocking systems.

Warranty

Warranty on EsiWelma products is valid for 12 months from installation date and no longer than 24 months from manufacturing date on the product. Installation data, stamp and signature on the data sheet filled in by the installer will be considered proof for warranty.

A copy of the warranty data sheet must be sent when returning the product under warranty.

Accessories

- UZR20.4** Four-relay card
- TUL40..** Gas calibration Kit
- TUS40** Handheld terminal
- CRG40** Gas collecting cone
- PAP40** Powerful jets protection

Dimensions and weight

Dimensions (HxWxD): 130x100x60mm.

Weight: 0.5Kg

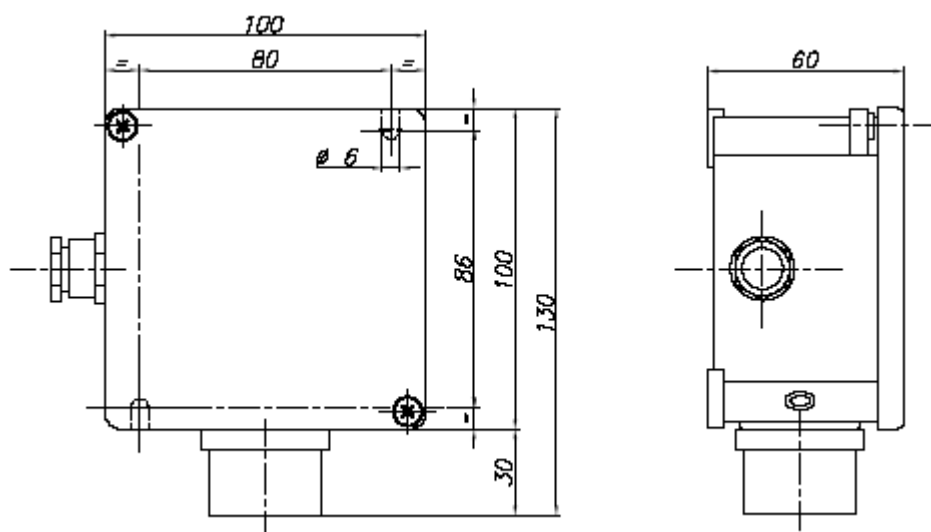

Installation data

| <i>To be filled in by Installer</i> | | <i>Installer's stamp and signature</i> |
|-------------------------------------|---------------------|--|
| Installation site: | | |
| Product order number: | | |
| Part Number: | Manufacturing date: | |
| Installation date: | Replacement date: | |

Routine checks

| <i>To be filled in by Installer / Service Personnel</i> | <i>Signature</i> |
|---|------------------|
| | |
| | |
| | |
| | |
| | |
| | |
| | |
| | |
| | |
| | |
| | |
| | |
| | |
| | |
| | |
| | |

Remarks

.....

.....

.....

.....

.....

.....

.....

.....

.....

.....

.....

.....

.....

.....

.....

.....

.....

.....

.....